

10 9 8 7 6 5 4 3 2 1

F

E

D

C

B

A

F

E

D

C

B

A

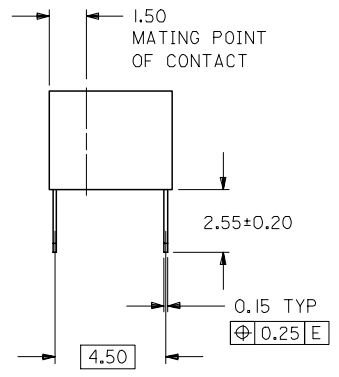
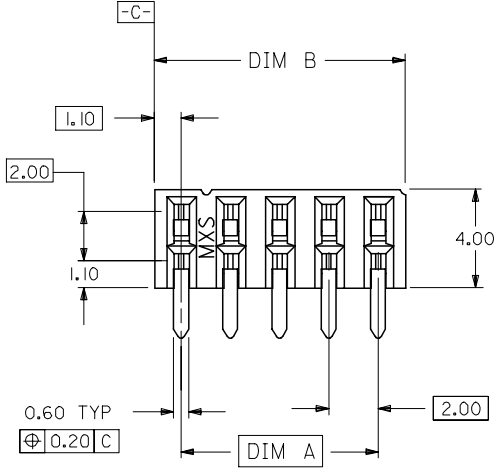

PART NO. LEGEND

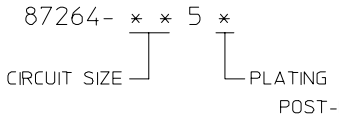

- 2 - 0.38um/15uin MIN. GOLD PLATE IN SELECTED AREA AND 2.54um/100uin MIN. TIN IN SELECTED AREA OVER 1.27um/50uin NICKEL OVERALL (IN TUBE).
- 3 - 0.76um/30uin MIN. GOLD PLATE IN SELECTED AREA AND 2.54um/100uin MIN. TIN IN SELECTED AREA OVER 1.27um/50uin NICKEL OVERALL (IN TUBE).
- 8 - 0.38um/15uin MIN. GOLD PLATE IN SELECTED AREA AND 2.54um/100uin MIN. TIN IN SELECTED AREA OVER 1.27um/50uin NICKEL OVERALL. (IN TAPE/REEL)
- 9 - 0.76um/30uin MIN. GOLD PLATE IN SELECTED AREA AND 2.54um/100uin MIN. TIN IN SELECTED AREA OVER 1.27um/50uin NICKEL OVERALL. (IN TAPE/REEL)

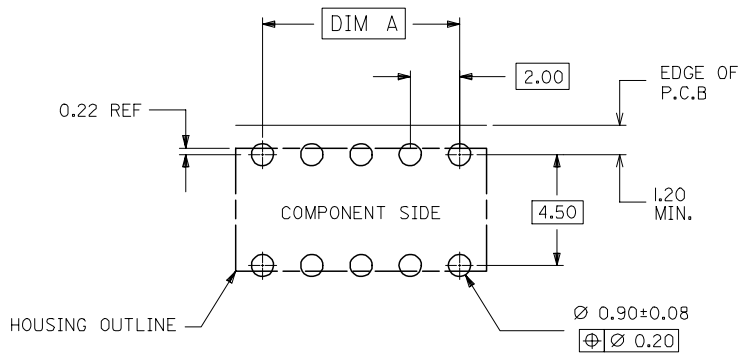
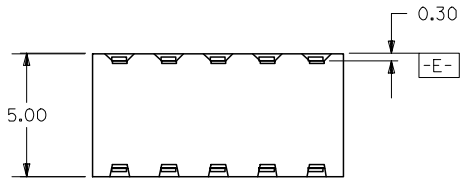

RECOMMENDED P.C. BOARD LAYOUT

- NOTES:
1. IO CIRCUIT SIZE SHOWN FOR ILLUSTRATION ONLY. SEE CHART FOR AVAILABLE PART SIZES.
 2. PLATING FINISH : TERMINAL - AS PER LEGEND
 3. RECOMMENDED PC BOARD THICKNESS IS 1.60 +/- 0.10mm.
 4. PRODUCT SPECIFICATION PS-87264 APPLIES.
 5. PART IS MATEABLE TO ALL MILLI-GRID HEADERS WITH MATING PIN LENGTH BETWEEN 2.50mm AND 4.20mm.
 6. TAPE & REEL OPTION IS SHOWN ON SHT 3 WITH 8 CKT ILLUSTRATION.
 7. PARTS SHALL BE PACKED IN MOISTURE BARRIER BAG.

ADD NOTE 7. EC NO: S2008-0422 DRWN:SKANG CHKD:ATSEE APPR:MLONG	2007/11/20 2007/11/20 2007/11/22	DESCRIPTION REV	QUALITY SYMBOLS	GENERAL TOLERANCES (UNLESS SPECIFIED)	DIMENSION STYLE	SCALE	DESIGN UNITS	THIRD ANGLE PROJECTION	
			$\nabla=0$ $\triangle=0$	mm INCH 4 PLACES ± --- ± --- 3 PLACES ± --- ± --- 2 PLACES ± 0.2 ± --- 1 PLACE ± --- ± --- ANGULAR ± 3 °	MM ONLY	NTS	METRIC	DRAWN BY: JWAN CHECKED BY: MLAI APPROVED BY: RWONG DATE: 1992/02/25 DATE: 1992/02/25 DATE: 1992/02/25	TITLE: MGRID, 2MM DUAL ROW HDR. SIDE ENTRY RECEPTACLE T/H MOLEX INCORPORATED
			DRAFT WHERE APPLICABLE MUST REMAIN WITHIN DIMENSIONS	SEE TABLE	MATERIAL NO. DOCUMENT NO.	SHEET NO.			
			SIZE: A3	THIS DRAWING CONTAINS INFORMATION THAT IS PROPRIETARY TO MOLEX INCORPORATED AND SHOULD NOT BE USED WITHOUT WRITTEN PERMISSION					

9 8 7 6 5 4 3 2 1

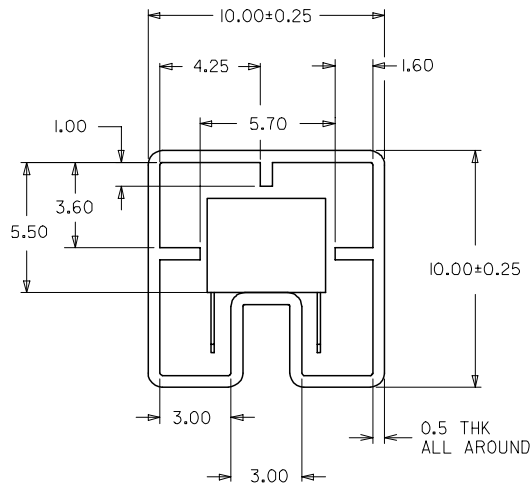
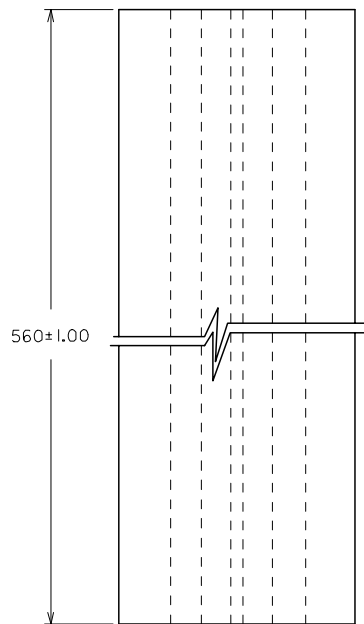

PART IN TUBE ORIENTATION.

PART NUMBER 0.38um GOLD PLATING \triangle_2	PART NUMBER 0.76um GOLD PLATING \triangle_2	CKT. SIZE	DIM A	DIM B
87264-065*	87264-065*	6	4.00	6.20
87264-085*	87264-085*	8	6.00	8.20
87264-105*	87264-105*	10	8.00	10.20
87264-125*	87264-125*	12	10.00	12.20
87264-145*	87264-145*	14	12.00	14.20
87264-165*	87264-165*	16	14.00	16.20
87264-185*	87264-185*	18	16.00	18.20
87264-205*	87264-205*	20	18.00	20.20
87264-225*	87264-225*	22	20.00	22.20
87264-245*	87264-245*	24	22.00	24.20
87264-265*	87264-265*	26	24.00	26.20
87264-285*	87264-285*	28	26.00	28.20
87264-305*	87264-305*	30	28.00	30.20
87264-325*	87264-325*	32	30.00	32.20
87264-345*	87264-345*	34	32.00	34.20
87264-365*	87264-365*	36	34.00	36.20
87264-385*	87264-385*	38	36.00	38.20
87264-405*	87264-405*	40	38.00	40.20
87264-425*	87264-425*	42	40.00	42.20
87264-445*	87264-445*	44	42.00	44.20
87264-465*	87264-465*	46	44.00	46.20
87264-485*	87264-485*	48	46.00	48.20
87264-505*	87264-505*	50	48.00	50.20

ADD NOTE 7. EC NO: S2008-0422 DRWNS:KANG 2007/11/20 CHKD:ATSEE 2007/11/20 APPR:MLONG 2007/11/22	QUALITY SYMBOLS $\blacktriangledown = 0$ $\triangle = 0$	GENERAL TOLERANCES (UNLESS SPECIFIED)		DIMENSION STYLE MM ONLY	SCALE NTS	DESIGN UNITS METRIC	THIRD ANGLE PROJECTION	
			mm	INCH	DRAWN BY JWAN	DATE 1992/02/25	MGRID, 2MM DUAL ROW HDR. SIDE ENTRY RECEPTACLE T/H	
		4 PLACES	± ---	± ---	CHECKED BY MLA1	DATE 1992/02/25		
		3 PLACES	± ---	± ---	APPROVED BY RWONG	DATE 1992/02/25	MOLEX INCORPORATED	
	2 PLACES	± 0.2	± ---	MATERIAL NO.		DOCUMENT NO. SD-87264-***50	SHEET NO. 2 OF 3	
	1 PLACE	± ---	± ---	DRAFT WHERE APPLICABLE MUST REMAIN WITHIN DIMENSIONS		SEE TABLE		
		ANGULAR ± 3°		SIZE A3		THIS DRAWING CONTAINS INFORMATION THAT IS PROPRIETARY TO MOLEX INCORPORATED AND SHOULD NOT BE USED WITHOUT WRITTEN PERMISSION		

PART NUMBER 0.38um GOLD PLATING \triangle_2 (IN TAPE/REEL)	PART NUMBER 0.76um GOLD PLATING \triangle_2 (IN TAPE/REEL)	CKT SIZE	DIM W	DIM F	DIM Bo
87264-085*	87264-085*	8	24.00	11.50	8.80

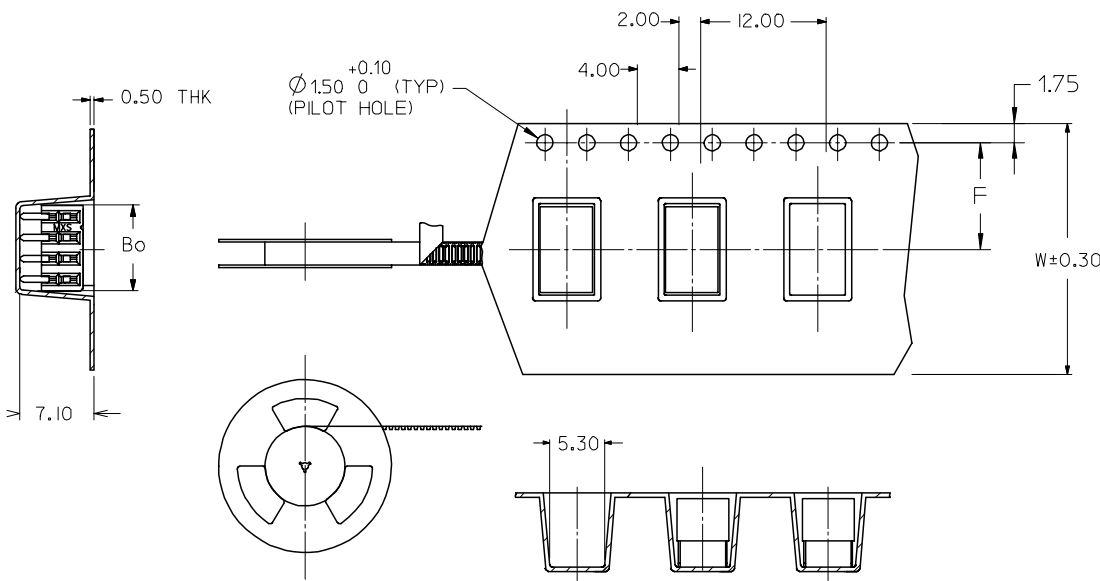

NOTES:

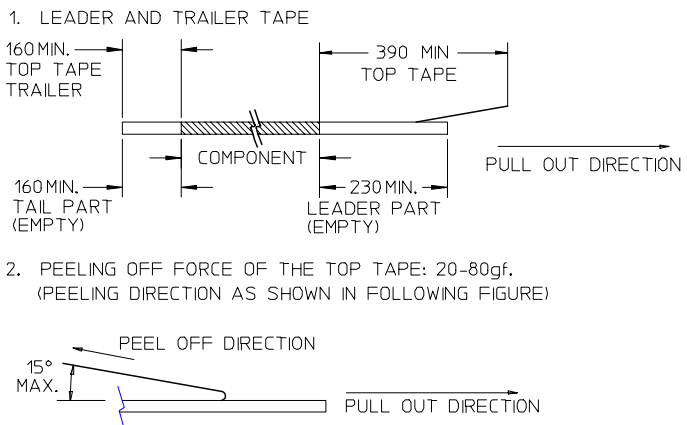

- 1. LEADER AND TRAILER TAPE
- 2. PEELING OFF FORCE OF THE TOP TAPE: 20-80gf.
(PEELING DIRECTION AS SHOWN IN FOLLOWING FIGURE)
- 3. PACKAGING STANDARD IS AS PER EIA-481.
- 4. TAPE & REEL QUANTITY = 600PCS/REEL

CUSTOMER PULL OUT DIRECTION →

ADD NOTE 7. EC NO: S2008-0422 DRWNS:KANG 2007/11/20 CHKD:ATSEE 2007/11/20 APPR:MLONG 2007/11/22	QUALITY SYMBOLS	GENERAL TOLERANCES (UNLESS SPECIFIED)	DIMENSION STYLE	SCALE	DESIGN UNITS	THIRD ANGLE PROJECTION																		
	$\nabla=0$ $\triangle=0$	<table border="1"> <tr> <th></th> <th>mm</th> <th>INCH</th> </tr> <tr> <td>4 PLACES</td> <td>± ---</td> <td>± ---</td> </tr> <tr> <td>3 PLACES</td> <td>± ---</td> <td>± ---</td> </tr> <tr> <td>2 PLACES</td> <td>± 0.2</td> <td>± ---</td> </tr> <tr> <td>1 PLACE</td> <td>± ---</td> <td>± ---</td> </tr> <tr> <td colspan="3">ANGULAR ± 3 °</td> </tr> </table>		mm	INCH	4 PLACES	± ---	± ---	3 PLACES	± ---	± ---	2 PLACES	± 0.2	± ---	1 PLACE	± ---	± ---	ANGULAR ± 3 °			MM ONLY	NTS	METRIC	
		mm	INCH																					
	4 PLACES	± ---	± ---																					
3 PLACES	± ---	± ---																						
2 PLACES	± 0.2	± ---																						
1 PLACE	± ---	± ---																						
ANGULAR ± 3 °																								
DESCRIPTION	DRAWN BY	DATE	TITLE																					
REV	JWAN	1992/02/25	MGRID, 2MM DUAL ROW HDR. SIDE ENTRY RECEPTACLE T/H																					
	MLA1	1992/02/25	MOLEX INCORPORATED																					
	RWONG	1992/02/25	SD-87264-**-50																					
	MATERIAL NO.		DOCUMENT NO.		SHEET NO.																			
	SEE TABLE		SD-87264-**-50		3 OF 3																			
	THIS DRAWING CONTAINS INFORMATION THAT IS PROPRIETARY TO MOLEX INCORPORATED AND SHOULD NOT BE USED WITHOUT WRITTEN PERMISSION																							